



- **Motor:** gasolina
- **Potencia:** 6.5 HP
- **Arranque:** manual
- **Desplazamiento:** 5 ft.³/ minuto
- **Presión máxima:** hasta 125 psi
- Hasta **75%** de eficiencia
- Construcción en **hierro gris**
- Refacciones originales **de fábrica**
- Garantía de **1 año**
- **Servicio técnico ***
- Tanque certificado bajo el **código ASME, sección VIII, División 1.**

* Se cotiza por separado.

ESPECIFICACIONES TÉCNICAS

Modelo y Potencia		Desplazamiento		RPM	Tanque		Presión
Modelo	HP	Mts. ³ x Minuto	Ft. ³ x Minuto	Compresor	Galones	Litros	Psi
I-153-HLG	6.5	0.15	5.40	950	30	114	125



55 4690 1671



55 8016 0405



ventas@bocomsa.com



@bocomsa

DIMENSIONES GENERALES/ CM

Modelo	HP	A	B	C	D	E	F	G	Peso KG
I-153-HLG	6.5	84.8	26.7	40.6	32.1	39.7	51.4	102	130

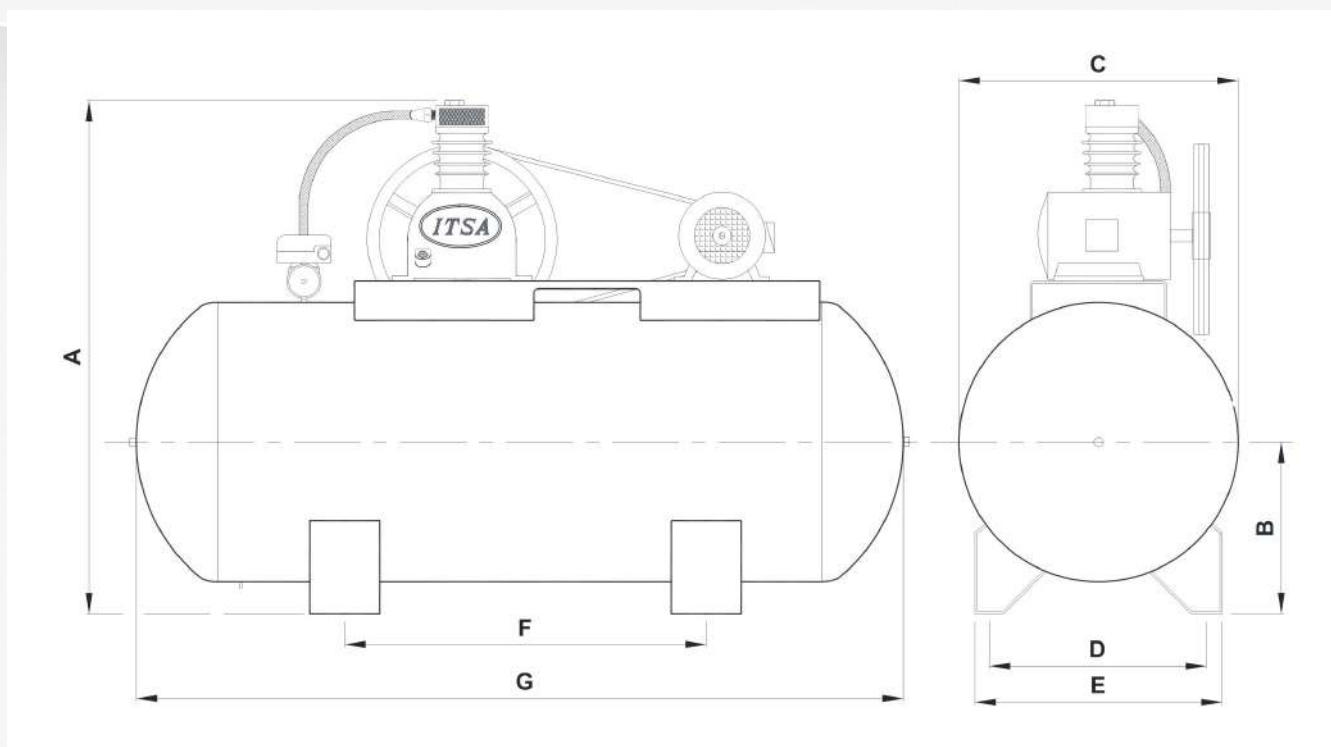

Imágenes ilustrativas.

USOS Y APLICACIONES COMUNES



- Talleres pequeños

  55 4690 1671

 55 8016 0405

 ventas@bocomsa.com

  @bocomsa